

USER'S MANUAL MODEL EV-180

U.S. Patent # 6,156,209

Thank you for purchasing an AquaC protein skimmer! Please read the following User's Manual carefully to become acquainted with some of the important features of your new skimmer. This high-performance filtration device must be installed and operated properly in order to achieve the best possible results.

WARNING!!! AquaC protein skimmers utilize an efficient form of air injection designed to produce enormous quantities of waste-laden foam. Failure to follow these instructions may increase the risk of skimmer overflow, flood, and electric shock. Care must be taken when installing and using your new filtration device.

Introduction to your AquaC High Performance Protein Skimmer

Your new skimmer will likely require several days of use before it begins to work properly. Trace quantities of oils and residues from the manufacturing process will prevent immediate skimming. In order to hasten this initial "break-in" period, wash the unit thoroughly with warm water (the use of soap or other chemicals is not recommended).

AquaC skimmers inject water through a molded aperture designed to create a powerful air-induction spray. As this spray bombards the water within the skimmer's main chamber, thousands of tiny bubbles are formed and allowed to react with unwanted proteins and waste. After the bubbles become coated with organic wastes, they rise up the foam tower and spill into the collection cup. Unlike traditional venturi or air-stone driven skimmers, your AquaC high performance skimmer processes aquarium waste with maximum efficiency.

Choosing a water pump

There are a variety of pumps, both submersible and external, that will run the EV-180 with excellent results. Since pump prices, availability, and technology are constantly changing, we are now publishing a frequently updated "pump chart" online at www.proteinskimmer.com. All the pumps listed have been thoroughly tested to guarantee a high level of performance. The online chart also lists some general commentary like associated noise, reliability issues, and heat production, which can be useful when selecting a pump.

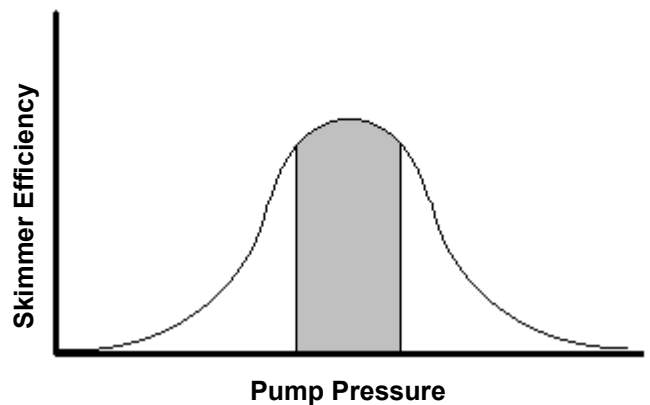

FIG. 1

- **Skimmer efficiency** can be defined and quantified in several ways and will be unique for different types of skimmers. We like to think of this term as a measure of pump pressure vs. performance (waste removal capacity).
- Powered by too small a pump, your EV-180 will not be running efficiently at all. Likewise, using too powerful a pump will be inefficient since excess energy is being wasted.
- The shaded region in Fig. 1 is where your skimmer will be running most efficiently. The pumps listed below fall in this region, and performance will be maximized while keeping energy costs down.

As of our last printing, the recommended pumps* for the EV-180 are as follows:

Pump	Submersible or External	Electrical requirements**	Comments
SEN 700	S, E	50 watts	We consider the SEN 700 to be the best value for the EV-180. It is powerful, inexpensive, and reliable
Mag Drive 700	S, E	55 watts	Performance with the Mag 700 will be approximately 5% lower than the SEN 700
Dolphin 800	S, E	50 watts	An excellent pump choice – be sure and add a valve on the pump output to throttle back the flow if necessary.
Iwaki 20 RLT	E	45 watts	Strong performance, excellent build-quality and long term reliability. Requires external plumbing and features very low heat output
Rio 3100	S	65 watts	The Rio 3100 is very powerful considering its low cost, and this is the least expensive pump that will run the EV-180 properly. This pump can only be used in a submersible installation

*It is extremely important to use the correct size pump to extract the skimmer's full potential. Be advised that pumps that are too powerful for your particular skimmer can potentially be hazardous and lead to water leakage or overflow.

**Listed electrical requirements are drawn from manufacturer's specs and have not been independently verified. Wattage is listed at a flow rate subject to 6 feet of head pressure, which simulates the AquaC spray injector.

Skimmer Features

The new EV Series skimmers are a significant advancement over the original design we released in 1998. We've listened to customer suggestions and comments and our new EV's incorporate many of the features hobbyists have been asking for. The new features include:

- Flanged and locking collection cup and cap - twist and release for super-smooth cleaning.
- Raised gate valve – the skimmer no longer needs to be raised in most sump installations!
- Redesigned exit plumbing virtually eliminates any microbubbles that can return to the sump.
- Larger mixing chamber (40% more volume) means greater contact time and waste removal.
- Side-mounted gate valve saves sump space and requires smaller overall footprint.
- Precision control air flow valve – easy tuning for wet or dry foam.
- John Guest “*Super Speed Fit*” fitting for quick airline connection on ozone models.
- Sealed foam tower means no more salt creep build-up.
- Auto-waste container compatible. Two and three liter containers are available.
- Redesigned interior baffling system reduces turbulence and increases contact time; the end result is a **two-fold increase** in foam production and skimming efficiency.

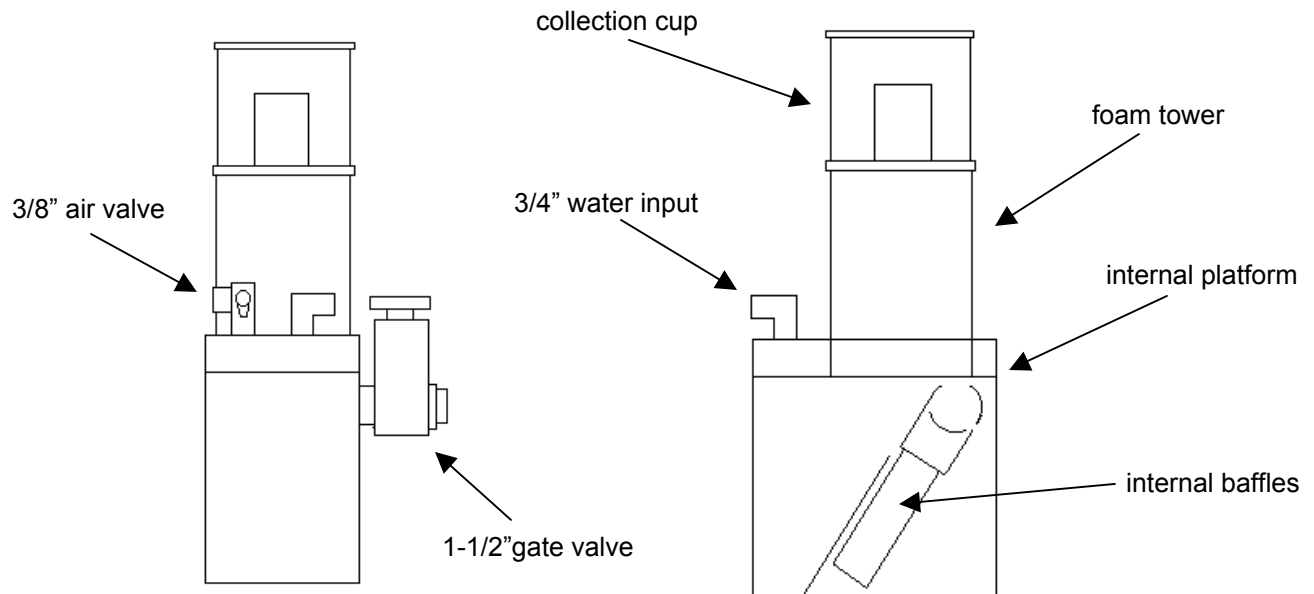

Skimmer Installation

First, carefully thread the gray exit valve into the skimmer body by hand - avoid overtightening. Your skimmer can be installed in several ways. The most common and recommended method is by mounting the skimmer and water pump inside the sump of your saltwater system. If you do not have space inside your sump the unit can be installed outside of the sump given that certain important criteria are met. **Regardless of the method you choose, it is mandatory that the correct water level inside your skimmer be maintained for safe operation.** The gate valve controls the water level inside the skimmer. During initial set-up, open the gate valve completely (counterclockwise).

In-sump installation is simple. The only requirement is that the gate valve must be higher than the sump water level. Since the gate valve is located 9" from the base of the skimmer, the unit can sit in a very deep reservoir without the need for a platform (fig. 2). If your sump is unusually deep (8" or more) you may need to place the unit on an elevated base so that the skimmer water level will be high enough to allow for proper drainage. A simple elevated platform can be constructed out of PVC pipe and eggcrate.

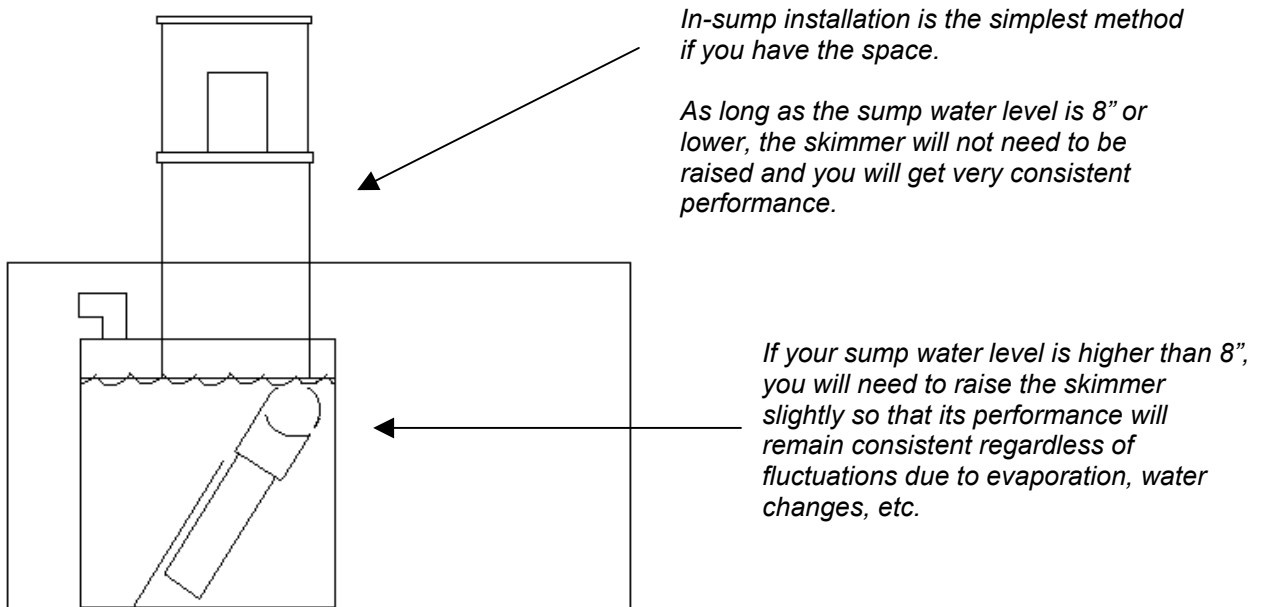

FIG. 2

When installed outside of a sump, the skimmer must be elevated high enough so that the processed water can drain back down to the sump unimpeded. This can be accomplished in several ways. The unit may be installed in-line alongside the sump (fig. 3) or you may place the skimmer on a platform alongside the sump and use a drain tube to bring processed water back to the sump. If you choose to use a drain tube (fig. 4), be sure that it is no more than three feet in length. Be aware that using a drainage tube in this fashion increases the potential for skimmer overflow – use large-diameter (1" or greater) tubing and elevate the skimmer high enough so that the water drains freely and unimpeded back down to the sump.

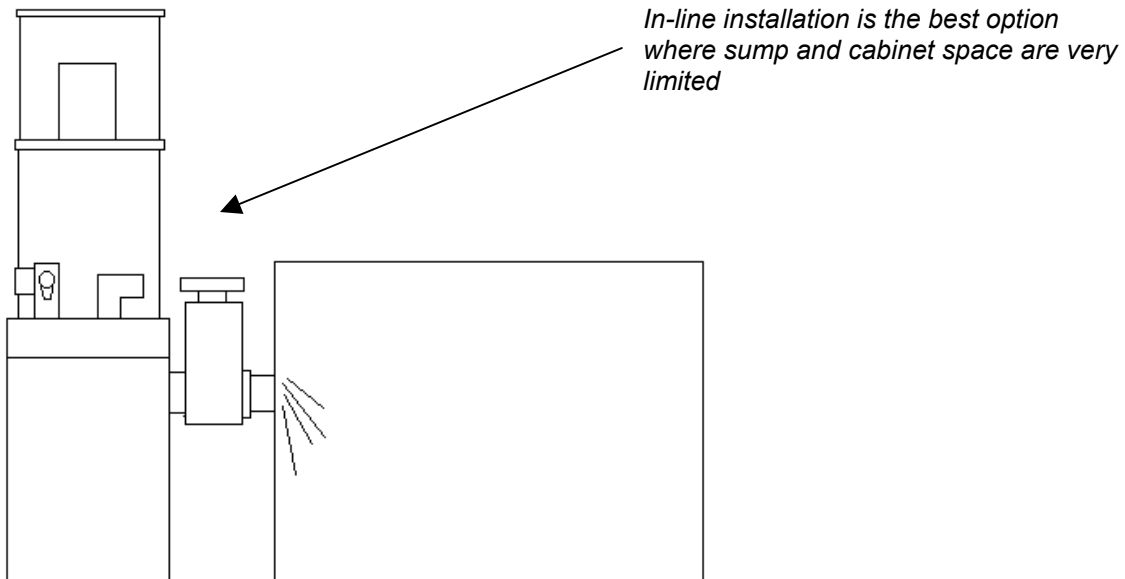

FIG. 3

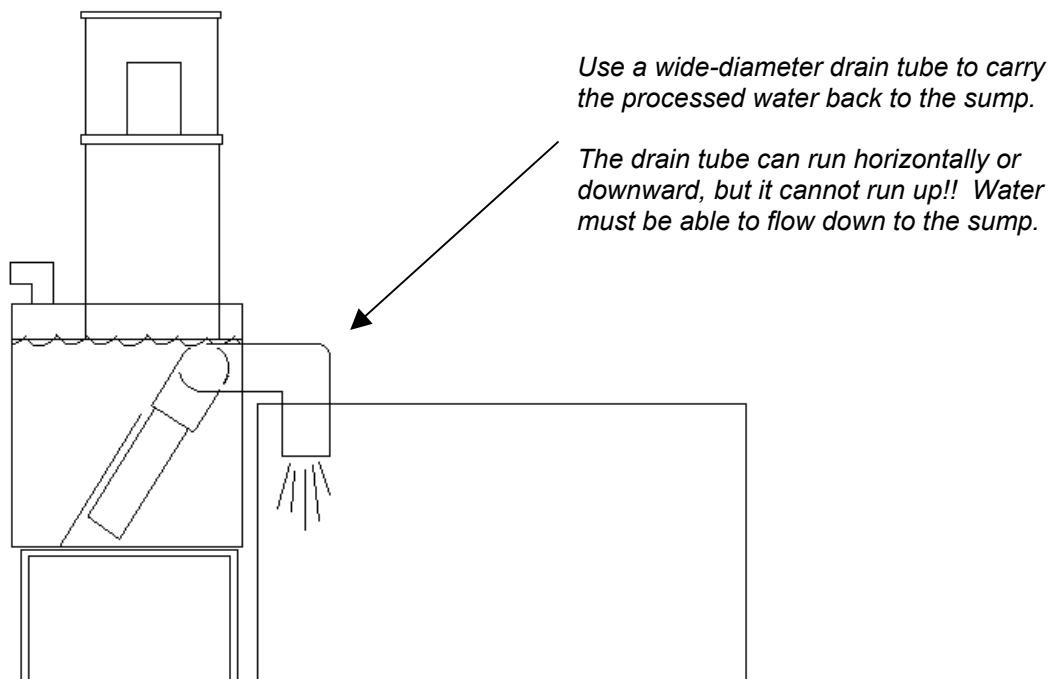

FIG. 4

Incorrect installation of your skimmer can increase the risk of leakage, overflow, and inconsistent foaming. Following these instructions exactly may reduce these risks.

Once the skimmer is placed in position, attach a length of $\frac{3}{4}$ " ID flexible hose to the unit's injection port inlet. A hose clamp should be used to secure the hose to the injection port as well as the pump. Open the gate valve and the air valve completely, and then turn the water pump on. The skimmer should begin to fill with water and air immediately.

Allow the skimmer several minutes to settle at a stable water height. With the gate valve completely open, the skimmer water level should rise approximately two-thirds of the way up the main chamber. Since your skimmer is made of translucent gray acrylic, you should be able to observe the interior water level (you might need to use a flashlight). Slowly close the gate valve one-half turn at a time until the water level rises within $\frac{1}{2}$ " of the internal platform. Once again, allow the skimmer several minutes to stabilize at this new height (fig. 5). **If you set the water level any higher than this, foam production may be impeded and you increase the risk of overflow and flood.**

Do not be surprised if your skimmer requires a few days to producing foam. Trace quantities of oils within the skimmer will initially prevent foam from building properly. Even though the unit may not be removing organic waste, it will vigorously oxygenate your aquarium water and benefit the health of the system immediately.

We recommend running the collection cup drain tube back to the sump during the first two weeks of operation. When the skimmer kicks in, it could very well overflow with foam and you don't want to be caught off guard.

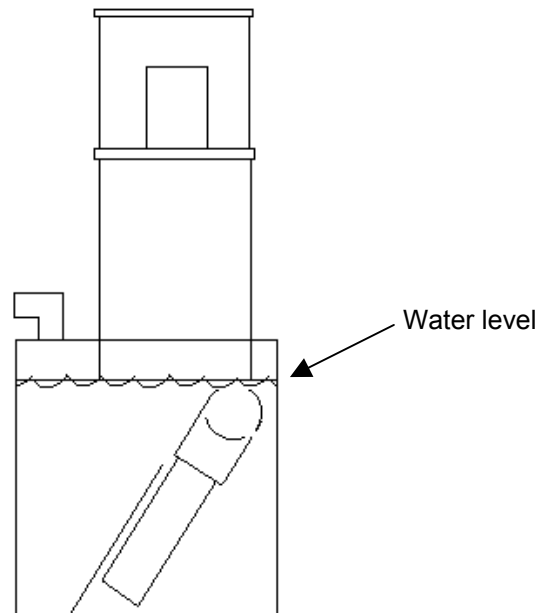

FIG. 5

After approximately one week your skimmer should be functioning near maximum efficiency. In some cases, this period may be reduced or extended. Rich, thick foam should rise up the foam tower and spill into the collection cup. At this point, **small adjustments** can be made to the exit valve to control the exact quality and quantity of foam you wish to collect. Some aquarists prefer to collect a very dry, dark foam, whereas others choose a setting which produces a steady yellowish liquid. Either will work fine. Always make small adjustments to the gate valve; determining the optimum water level will take some time and experience. **Do not raise the water level inside the skimmer more than 1-2" above the waterline shown in figure 5.** Doing so will immediately cease efficient foam production, and increase the risk of overflow. Be patient during the skimmer's first few days of operation since it will take some time and experience to find the best water level. Constant fiddling with the gate valve will slow this process.

Once you do find the "sweet spot" (i.e. the best water level for maximum efficiency) your skimmer should need no further adjustments. We recommend leaving the blue air valve completely open. Unlike venturi/Beckett type skimmers, AquaC spray injection skimmers perform best when the airflow is unrestricted.

Congratulations! Your new AquaC High Performance Protein Skimmer is completely installed and is already beginning to improve your water quality!

Maintenance

AquaC protein skimmers require very little maintenance. In order to achieve the maximum amount of efficiency from your skimmer, it is recommended that you clean the foam tower and collection cup at least twice a week. This is easily accomplished by wiping the foam tower with a rag or paper towel and rinsing the cup thoroughly under warm water. The collection cup can be quickly disassembled for hassle-free cleaning. Never use cleaners or soap to wash any part of the unit. The thick brown scum that rapidly accumulates along the sides of the foam tower can impede the performance of the skimmer. Therefore, it is wise to clean the foam tower often. If possible, protein skimmer cleaning should be a daily priority.

We highly recommend using an auto-waste container with the skimmer to reduce the risk of skimmer overflow and flood. Chemical disturbances in the tank may cause the unit to produce copious amounts of foam that can cause a flood. If you do not use an auto-waste container, we recommend keeping the waste jug inside your sump so that if it overflows you will avoid a flood.

The spray injector is fully accessible and can be removed easily for cleaning. Simply unscrew the $\frac{3}{4}$ " injector barb and debris, calcium build-up, etc. can be removed if necessary. The injector generally does not require regular maintenance and in many cases will last for well over a year without service.

Troubleshooting

1. Skimmer isn't producing very much foam

- A. Give the skimmer at least two full weeks of continuous operation to reach its maximum potential. If the unit still fails to produce foam, check the water pump for problems. A faulty or underpowered pump will not drive the air-induction injector properly, which will lead to low levels of foam production.
- B. Check the water level inside the skimmer's main chamber. An incorrect water level will prevent proper foam production. Adjust the gate valve so that the interior water level is near the level of the internal platform (fig. 5).
- C. AquaC protein skimmers feature an intense air flow-thru rate, which means that they are highly influenced by oils, fats, and chemicals dissolved in the aquarium water or air source. You will notice a drastic but temporary reduction in foam production after fish feedings or other events that introduce chemicals into the water. Foam production should resume within several minutes to a few hours, depending on the nature of the chemical disturbance. This should not be any cause for concern since your high performance skimmer will rapidly make up for any time lost due to the disturbance.
- D. Open the blue air valve.

2. Skimmer water level is too high

- A. Make sure that the water pump is not too powerful for the unit.
- B. Raise the skimmer higher by placing it on an elevated platform so that the processed water can freely exit unimpeded.
- C. Open the gate valve until the water level is at the proper height.

3. Skimmer is overflowing with wet foam

- A. Lower the water level inside the skimmer until foam production becomes manageable. Every tank is unique and depending on your system bioload and the additives you use, you might need to run a lower water level in order to collect a dry foam.
- B. If you are using “stress coat” additives, water conditioners, or other trace element/feeding solutions the skimmer may react by overflowing with foam. We recommend against the use of any additives that cause your skimmer to foam excessively.
- C. You can control the amount of foam the skimmer produces by tuning the blue air valve. If you are getting too much foam production, you can either lower the water level, close the air valve partially, or try a combination of both. With time and experience you will find where the best skimmer performance is. In our tests the best performance is attained with the air valve open 100% and the water level lowered to produce a moderately dry waste product.

4. Skimmer releases microbubbles back to the sump

- A. The skimmer should release very few microbubbles once it is broken in. During the first two weeks of operation it will release a larger number of bubbles since it is still in the break-in process.
- B. If you are running the skimmer with too powerful a pump, microbubbles will escape back to the sump. Use the correct size pump with the skimmer.
- C. After fish feedings, water changes, or trace element additions it is normal for the skimmer to release microbubbles for a short period of time. These will normally subside within several minutes to an hour or two.
- D. Don't mistake bubbles created from drain splash for microbubbles – These bubbles are usually larger and present less of a problem to return pumps.

If you have any other problems that are not listed above, do not hesitate to call or email our technical staff for help! Customer service is one of our top priorities and we will do our best to find a solution to your problem.

Please include the following information in your technical support emails or phone messages:

- Tank size, age, and type (fish-only, SPS reef, mixed reef, etc.)
- Any supplemental filtration used (i.e. ozone, w/d filter, other skimmers, etc.)
- Additives and foods used as well as dosing schedule/amounts.
- Skimmer model, pump model, and method of installation.

AquaC Limited Warranty

This AquaC protein skimmer is guaranteed to the original purchaser to be free from defects in materials and workmanship for a period of ninety days from the date of purchase.

This warranty is limited to the original purchaser at retail and is not transferable. The warranty shall only cover defects arising from workmanship or normal usage. AquaC shall accept no responsibility whatsoever for malfunctions, failures, or defects arising from misuse, alteration, modification, or improper installation or maintenance of this product.

At the time of request for warranty service, the purchaser must present proof of purchase documentation that includes date of purchase. Upon confirmation that the malfunction is a result of a defect covered by this warranty, AquaC shall, within ninety (90) days after receipt of the product, at its option, repair or replace the defective product.

In no event shall AquaC be liable for direct, indirect, incidental, or consequential damages involving this product or its use.

Depending on your state of residence, some of the above terms may not be applicable.

AquaC, Inc.

Visit us online at... www.proteinskimmer.com

7965 Silverton Ave. Ste. 1314
San Diego, CA 92126
858-689-1121 sales desk
858-564-3419 fax

Technical Questions?? email support@proteinskimmer.com